

1. SUPPORT FABRICATION ACCORDING TO HYDRA ALPHARD PROJECT OR CLIENT PROJECT.

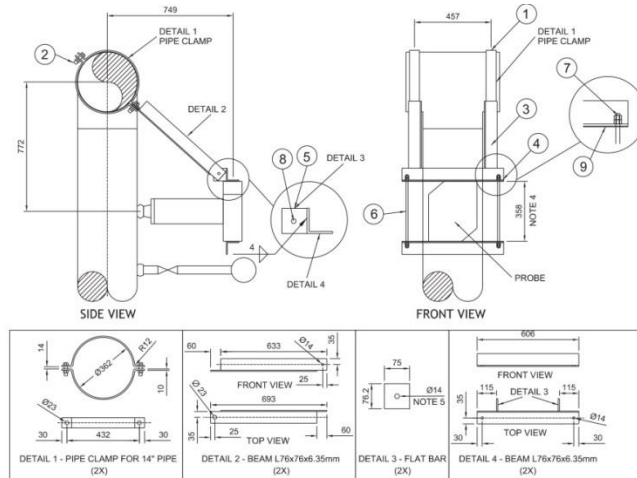

2. DIMENSIONAL INSPECTION, VISUAL AND DYE PENETRANT.

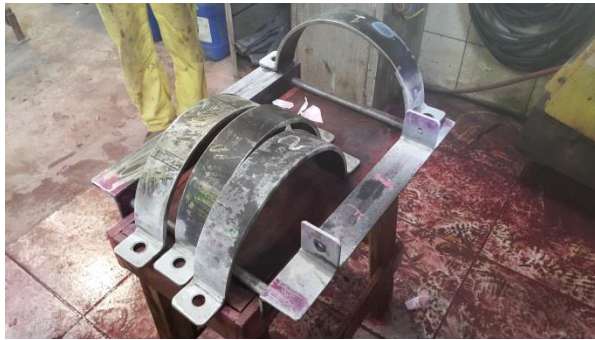

3. SUPPORT ASSEMBLY.



SUPPORT FABRICATION

4. BLASTING Sa 2 1/2



5. PAINTING ACCORDING TO CLIENT SPECIFICATION.



6. SUPPLYING BOLTS AND NUTS WITH XYLAN 1424 BLUE COATING ACCORDING TO CLIENT SPECIFICATION.

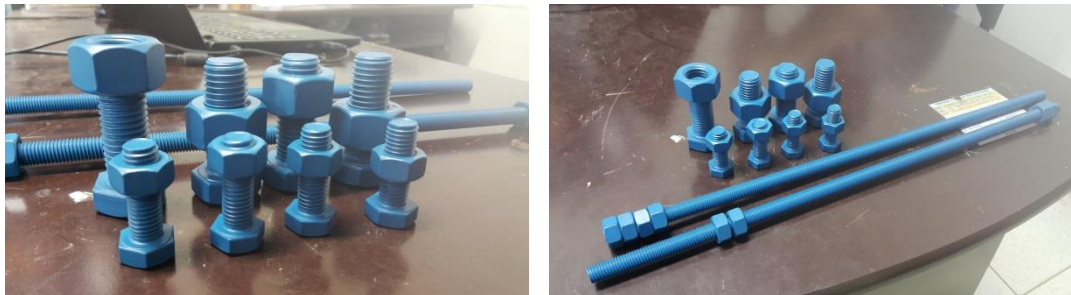

7. EQUIPMENT PACKED WITH BUBBLE PLASTIC IN EXPEDITION.

